

Experiment 4

Chem 110 Lab

LABORATORY TECHNIQUES

I. INTRODUCTION

In today's lab you will be assigned an equipment box and learn to identify laboratory equipment and practice setting up equipment for various lab procedures.

A. Equipment Box Assignment

Your instructor will assign you an equipment box and give you an inventory sheet for you to complete. Place your equipment box in the drawer at your station. Remove the equipment to your bench top and inspect each item for chips or cracks. If the item is broken or chipped or cracked set it aside, but if it is not, return it to your equipment box and put a check mark on the inventory sheet. If an item is missing, write the word "missing" next to it on the inventory sheet. Ask your instructor to verify that it is missing and initial your inventory sheet. After you have checked all of your equipment, take your inventory sheet and any chipped, cracked or broken equipment to the stockroom (see below) and the stockroom will replace missing and broken items. Upon receiving the items, sign your inventory sheet, write your student I.D. number on it, and turn it in to the stockroom.

Before you leave the lab each day, you must clean and dry (as much as possible) all of your equipment. Never store dirty equipment or any reagents in your equipment box. If you pack the equipment box carefully, you may be able to find space for your goggles.

B. Chemistry Stockroom

The Chemistry stockroom (its sign says "preproom") is located in across from S -222 and S-224, halfway down the hall. The stockroom will be open during your assigned lab time as well as at other times. Stockroom hours are posted outside the door. To obtain extra equipment needed for experiments you will need to fill out a lab slip (Bring your own pencil). For example, let's say you need two 500 mL beakers and one 50 mL graduated cylinder for your experiment, you would fill out the form (at stockroom counter) as follows:

Name _____ Jane Doe _____	
Room No _____ S-219 _____	
Section: _____ Date _____	
ITEMS:	----- Ticket number for your lab section
2 500 mL beaker	
1 50 mL graduated cylinder	

NOTES:

- Fill out the lab slip before summoning the stockroom attendant.
- Students are not allowed in the stockroom.

II. EXPERIMENT

A. Handling Reagents

To fill in the blanks below, consult Safety for People & Chemicals.

1. To carry a solid chemical, I will use _____
or _____

2. To carry a liquid chemical, I will use _____, and not a graduated cylinder.
Why? _____

3. Explain how you would weigh a liquid sample. (Use complete sentences):

4. Explain how you would weigh a solid sample (Use complete sentences):

5. What should you do with leftover solids?

or _____

6. What should you do with leftover liquids?

or _____

7. What is the soap located in the dispenser above the large sinks used for?

B. Perform the following lab techniques with your instructor.

1. Light and adjust the flame on a Bunsen burner:

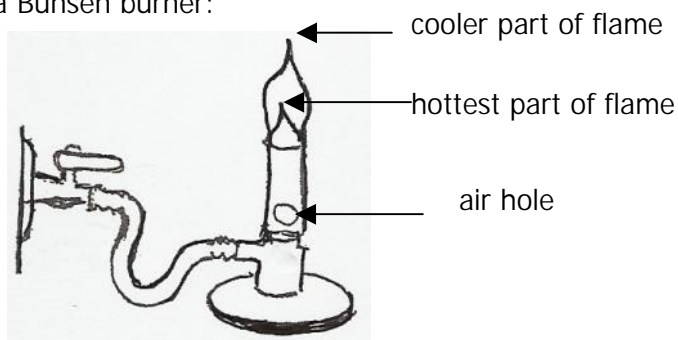

2. Set-up a ring stand with an iron ring:

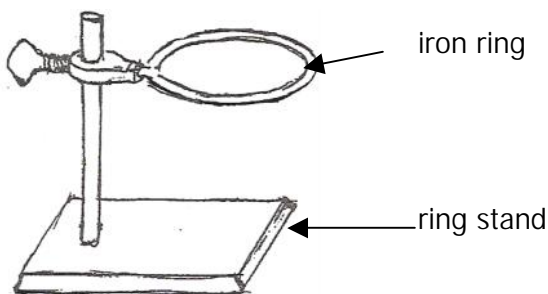

3. Add tap water to a 250 mL beaker until it is about 2/3 full and then warm the water:

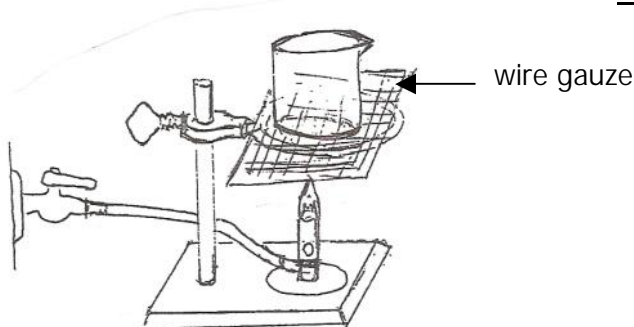

4. Use evaporating dish tongs to place an evaporating dish on top of the 250 mL beaker. Turn up the flame and bring the water to a boil. You now have a steam bath.

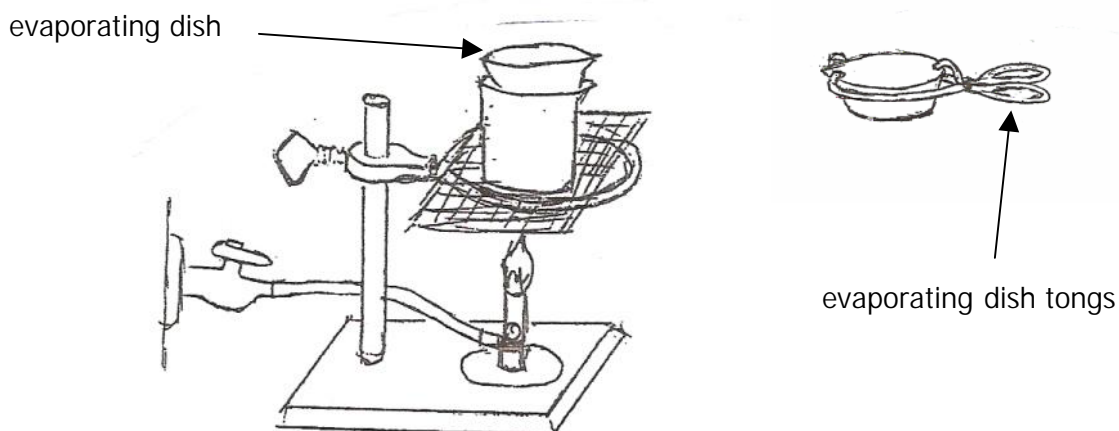

Heating the material over the steam bath allows you to heat at the temperature of the water vapor rather than at the much higher temperature of the Bunsen burner flame.

5. Use evaporating dish tongs to remove the evaporating dish.
6. Use beaker tongs to remove the beaker of hot water.

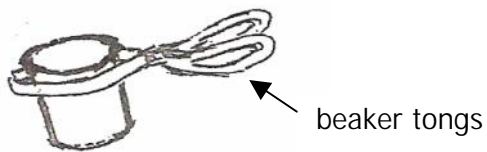

7. Heat about 50 mL of water in a 125 mL Erlenmeyer flask, clamping the neck of the Erlenmeyer to the ring stand using a utility clamp:

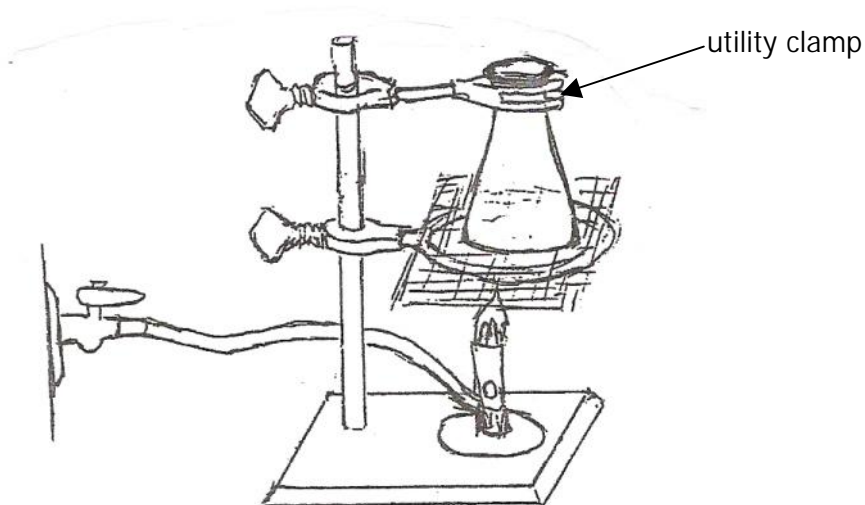

8. Turn off the flame and carefully remove the Erlenmeyer flask with the utility clamp. Then carefully remove the HOT wire gauze from the ring using crucible tongs.
9. Place a very small amount of sand in your crucible. Place it in a clay triangle on the ring. Heat the sand in the crucible.

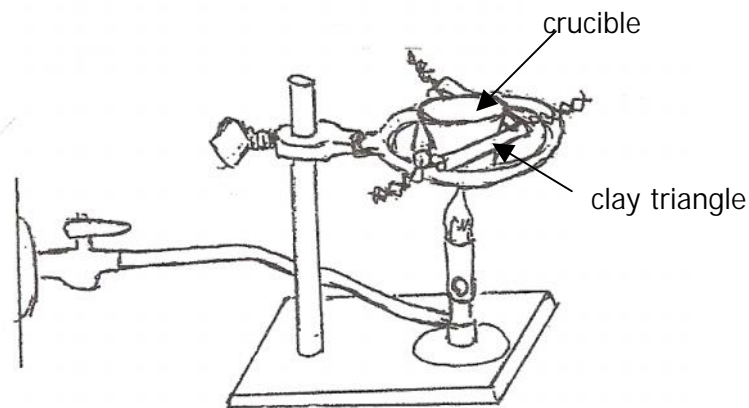

10. Use crucible tongs to set the hot crucible on a wire gauze or the base of the ring stand to cool. Save the sand for step 11.

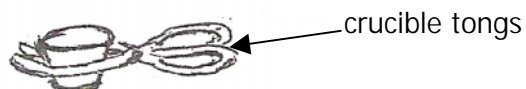

11. Pour the sand into a 50 mL beaker and add approximately 40 mL of water and stir with your glass stirring rod. Allow the sand to settle to the bottom of the beaker and then decant the water into your 150 mL beaker.

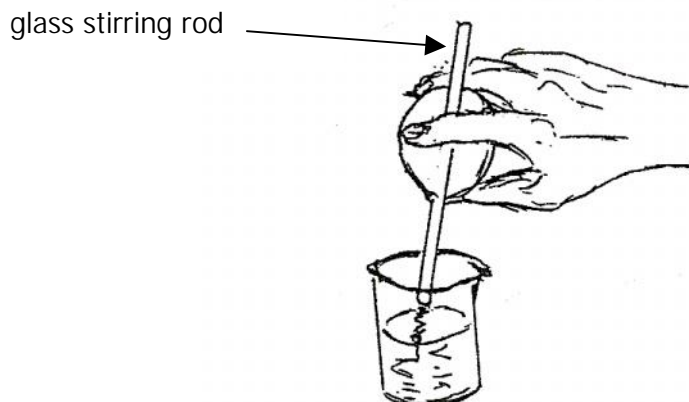

12. Use the rubber policeman (attached to the glass stirring rod) as a spatula to remove the sand that remains in the 50 mL beaker, transferring the sand to your evaporating dish and saving it for step 13.
13. Set up a filtration apparatus as shown below. Place your funnel in the ring. If the ring is a small one the funnel will just fit in it. If it is a larger ring you will need to put your clay triangle on top of the ring and place your funnel in the clay triangle. Place your 250 mL beaker beneath the funnel and adjust the height of the ring on the ring stand so that the stem of the funnel is touching the inside wall of the beaker. (This will prevent the filtrate—the liquid that passes through the filter paper-- from splashing as it passes out of the funnel.)

Get a piece of filter paper from the labeled drawer. Fold the filter paper in half, then in half again. Open the paper so that three thicknesses are held together and a cone is formed. Place the filter paper in your funnel and moisten it with a small amount of deionized water. Gently press the edge of the paper against the funnel. It should make a seal against the plastic.

Add the sand to the water you decanted into the 150 mL beaker. Mix the sand and water and filter the mixture through filter paper.

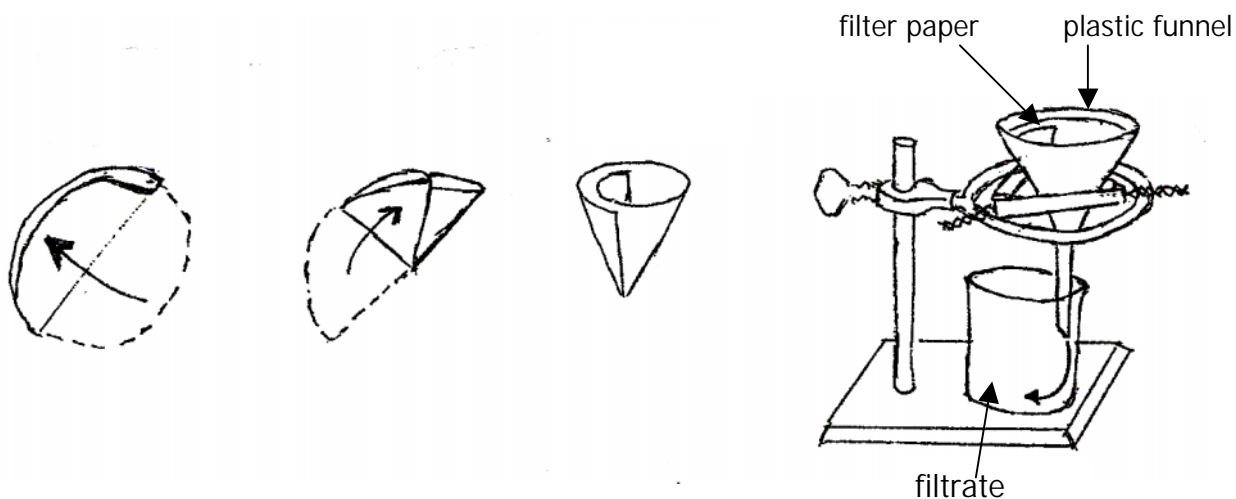

The filtrate should be clear.

14. Accurately measure 3 mL of deionized water in your 10 mL graduated cylinder, using your medicine dropper to make sure the bottom of the meniscus is right at the 3 mL mark. Pour the water into a small test tube. Look at the water in the test tube and decide the approximate height, in inches, of the liquid in the test tube

_____ inches

Remember this and when your experiment calls for approximately 3 mL of liquid you can estimate the amount without using your graduated cylinder.

15. Hold the test tube with a test tube holder near the top of the test tube. Heat the water gently by placing the test tube in the cooler part of the flame. When heating the water in the test tube, make sure the test tube is held sideways and along the length of the bench.

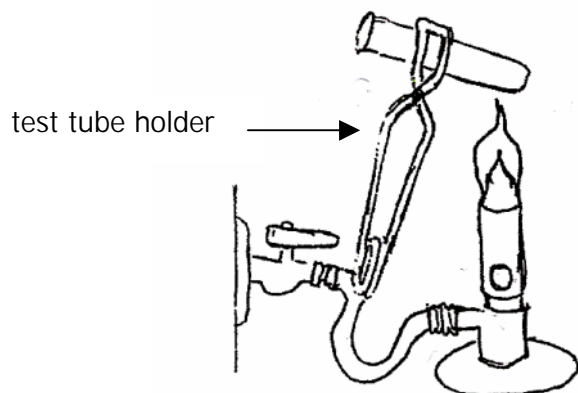

16. Your instructor will demonstrate the correct way to remove a ground glass stopper from a liquid reagent bottle and hold it without contaminating the stopper or liquid.

Report Experiment 4
Chemistry 110 Lab

LABORATORY TECHNIQUES

Name _____ Date _____
(last) (first)

Instructor's Initials _____

PLEASE CAREFULLY PRINT YOUR RESPONSES TO THE FOLLOWING:

1. Describe the procedure for lighting a Bunsen burner. Use complete sentences in English.

2. What is a steam bath used for?

3. Describe how you would weigh a liquid sample. Use complete sentences in English.

4. Describe how you would weigh a solid sample (Use complete sentences):

5. Give the names of the 2 process illustrated below, then write a brief description of each process. Use complete sentences in English.



a. _____

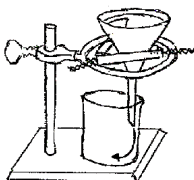

b. _____

